

HELITRONIC G 200

COST-EFFICIENT TOOL GRINDING MACHINE WITH A SMALL FOOTPRINT



HELITRONIC G 200

APPLICATION

- Grinding rotationally symmetrical tools with small to medium diameters for the metalworking and woodworking industries
- For production and/or regrinding
- Complete machining in a single clamping
- Materials include HSS, carbide, cermet, ceramic

MACHINE

- Low-vibration, solid mineral cast bed and C-frame construction
- X, Y, Z linear axes with ballscrew drive
- Rotating A, C axes with high torque motors
- Belt-driven spindle with two ends
- Each spindle end can take up to three grinding wheels
- FANUC, the global standard for control equipment
- Loading system: Top loader (option)

SOFTWARE

- HELITRONIC TOOL STUDIO, CAD/CAM software for design, programming, simulation and production
- Numerous software options to enhance performance and increase efficiency

« In addition to the small footprint, the machine impresses with its ergonomic design, which ensures easy operation and accessibility of the working area. The machine base made of mineral cast converts the high dynamics of the digital drives with low vibration into grinding precision. »

SIMON KÜMMERLE, PRODUCT MANAGER HARDWARE

YOUR BENEFIT

Tools with small to medium diameters can be produced and resharpened on a footprint of only 2.3 m². Thanks to the solid mineral casting, the machine has a high vibration damping and temperature insensitivity for highest grinding precision.



HELITRONIC G 200 – Space-saving, ergonomic design, simple operation and good accessibility



[FURTHER DETAILS](#)

INNOVATIVE WALTER GRINDING TECHNOLOGY

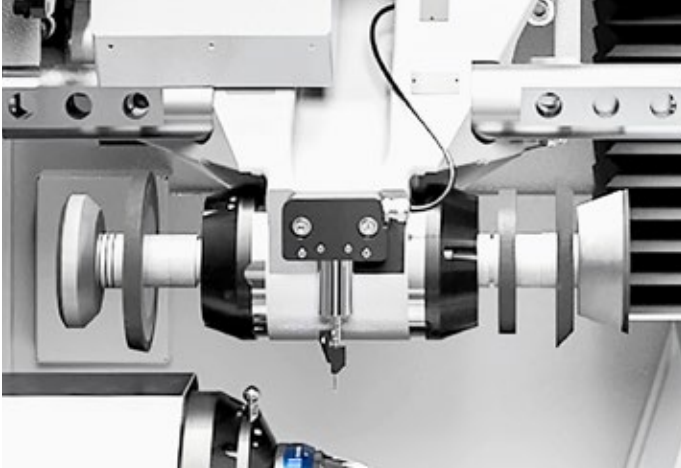

Belt-driven spindle

The belt-driven spindle with two ends can take up to six grinding wheels. The different grinding wheel sets are allocated to the relevant spindle along with the wheel measurement data.

C-frame construction

The C-frame construction and the mineral cast bed with its high weight and extreme rigidity converts the high dynamic performance of the digital drives into low-vibration grinding precision.

EFFICIENT AND EASY TO USE

For the production and sharpening of rotationally symmetrical tools for the metal and wood working industry in one clamping. Diameter range 1 to 125 mm, machining length up to 235 mm, piece weight up to 12 kg.

Example tools (from left to right):

Thread milling tool, stepped drill bits, carbide reamer, carbide spiral drill bit, medical drill bit, rotary milling tool, micro milling tool



TOP LOADER AUTOMATION OPTION

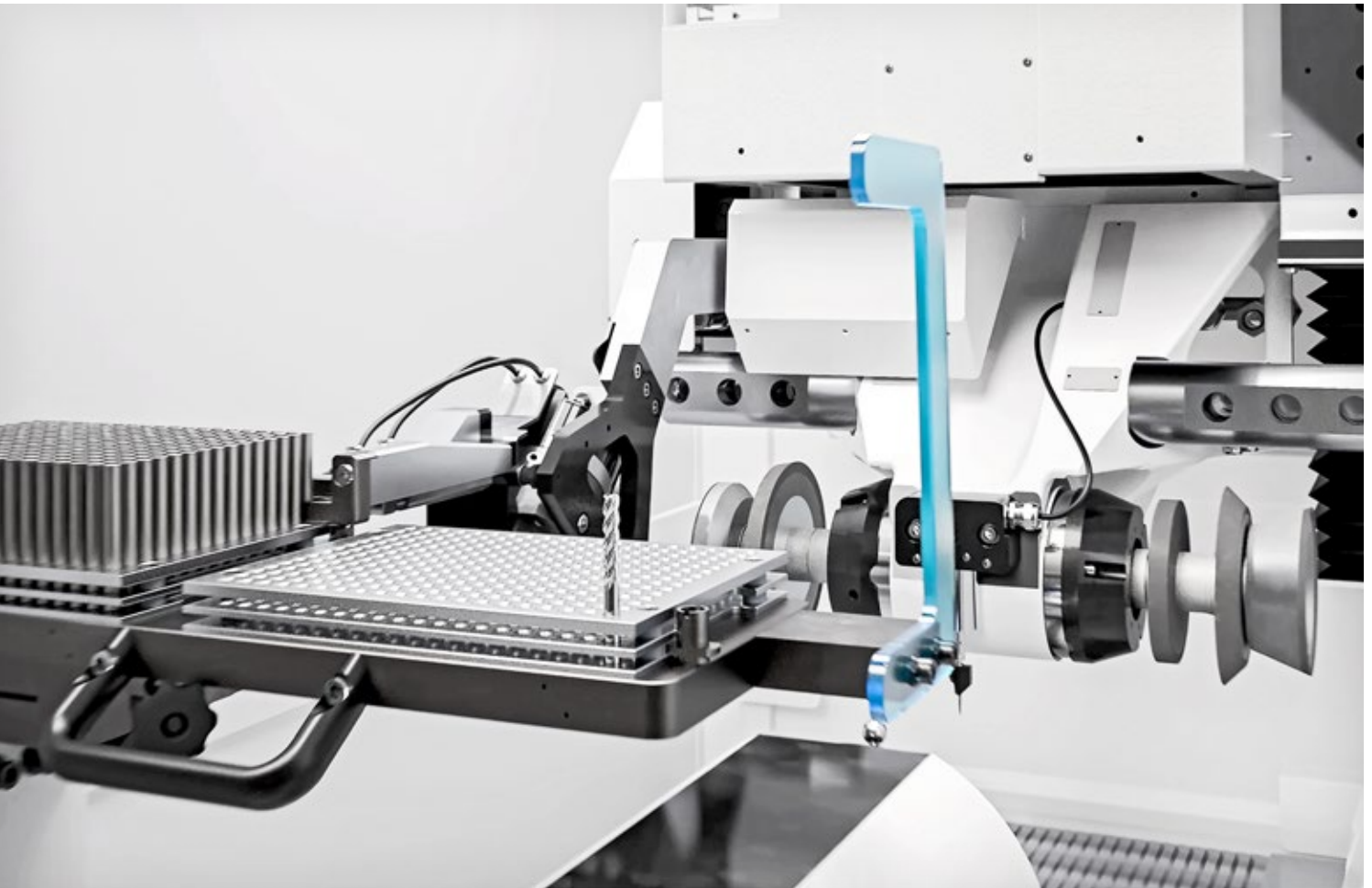

“Top loader” option

This space-saving and inexpensive automation solution is integrated directly into the machine envelope. Featuring an automatic teaching capability setup times are reduced to a minimum. Depending on the tool diameter, the Top loader offers a maximum of 500 places for tools.

Tool capacity, max. (sample diameters):

- 500 tools: diameter 3 mm
- 99 tools: diameter 10 mm
- 42 tools: diameter 16 mm

OTHER OPTIONS



Automatic, electrical measurement of the machine reference

Now use the advantages of the automatic, electrical measurement of the machine reference in the grinding and eroding machines from WALTER.

- Maximum precision of measurement results through exact positioning of the axes via electrical contact
- Automatic mechanical inspection of the dimensional accuracy of the C axis
- Significant time savings with automatic operation in comparison to the manual measurement method
- Valuable working time of the employees can be used for other tasks
- Eliminates errors caused by the human factor
- Short amortisation time for your investm

APPLICATION SOFTWARE FOR TOOL MACHINING

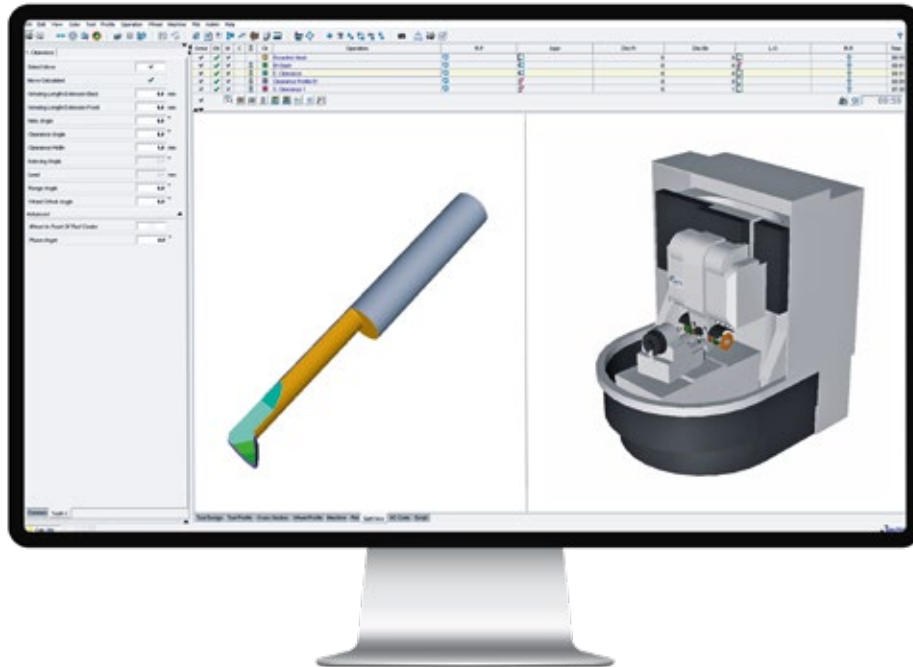

HELITRONIC TOOL STUDIO –

Operating convenience with all grinding applications

HELITRONIC TOOL STUDIO is the WALTER way to the perfect tool. According to the tried and tested method of “What you see is what you grind”, just a few mouse clicks are all that separate you from producing the perfect precision tool: Design, programming, simulation and production.

HELITRONIC TOOL STUDIO: This combines ease of programming with the greatest possible flexibility. With the HELITRONIC TOOL STUDIO, only a little work is needed by the user to program machining steps and movement sequences for both rotationally symmetrical standard tools and for special tools.

The tool shown on the screen corresponds exactly to the tool which will then be produced. This means that, as early as the design phase, the result can be checked and, if necessary, corrected thanks to the true-to-life 3D simulation.

The operator can quickly find the tool type, the parameters to be entered and the tool by using the assistant. WALTER provides programme packages for all standard tool families, which make handling significantly easier.

EFFICIENCY OPTIONS

- Analysis of the centre of gravity
- Balancing the tool

„Tool Balancer“

The Tool Balancer is an easy way to analyse, and balance out if necessary, centre-cutting tools with an odd number of flutes (unevenly divided tools) or special tools. The efficiency-increasing method has two core functions: One is to analyse the centre of mass and the other is to automatically balance the tool using different techniques. The approach is simple and can be mastered with just a few mouse clicks. Analysis during the development phase means that the process of prototype production can be significantly shortened. Balanced tools have a longer tool life, can machine at higher speeds, produce higher-quality surfaces and result in less wear-and-tear. Asymmetrical tools are well-suited to machining processes with high rotation speeds up to a point where significant imbalance forces occur.

- Permanent set-actual comparison for the torque

„Adaptive Control“

By permanently comparing the machine loading, grinding can be made more efficient and simultaneously safer. If the load increases, the feed will be decelerated accordingly. If the load decreases, the speed is increased accordingly. With AC grinding, alternating loads on the grinding wheels will be prevented by a continual load. Any possible overloading of the grinding wheels is excluded.

- Up to 30 % time saved
- Optimum feed rate
- Optimize existing IDNs

„Feedrate Optimizer“

This enhancement to the HELITRONIC TOOL STUDIO provides the ideal options for feed control and for monitoring the grinding wheel and machine load. Depending on the tool type, the time savings can be up to 30 %. Feed optimisation uses the findings entered into the HELITRONIC TOOL STUDIO in relation to grinding movements, and the grinding wheel and tool simulation model in order to calculate the current grinding wheel and machine loads and set the optimum feed at any time. Movements with low wheel loads will be accelerated and, this is particularly important, movements where the desired wheel load is exceeded are slowed down. Even existing IDNs can be conveniently optimised with just one click. First, the profile of the grinding wheel load is determined via a progressive simulation analysis. Then, the feed is optimised in such a way that the wheel load remains constant during the entire processing run.

- High ease of operation and time saving with minimal training requirements
- Import or export of DXF files

„Sketcher“

Do you sometimes wonder why you need to draw tools separately in a CAD program and then recreate the desired tool in another software package? Thanks to the “Sketcher” option, this is now a thing of the past. You can now create CAD drawings, program tool ID numbers and grind the desired tool in a single software package thanks to the “Sketcher” option. HELITRONIC TOOL STUDIO includes an integrated CAD system with an intuitive icon-based user interface for creating tool and grinding wheel drawings. The tool simulation and CAD drawing features are linked in HELITRONIC TOOL STUDIO, meaning that each parameter modification is not only reflected in the simulation model but also in the associated CAD drawing. CAD drawings can be re-used for different tools as the CAD elements used for other tool ID numbers attempt to re-connect with the tool simulation model. Users can also import and export DXF drawings, and save drawings as PDF documents. Your benefit: save time and resources through a central software solution!



GLOBAL STANDARD OF CONTROL TECHNOLOGY

With the FANUC control unit, WALTER relies on the global standard of control technology. For the user, this means the highest degree of reliability, availability and operating comfort.

WALTER, famous for tool grinding, and FANUC, the No. 1 in CNC control units – together an unbeatable team.

- Multifunction touchpanel with 21.5" screen
- Multi-processor system – high system security
- FANUC bus for digital drives – disruption-free communication
- CNC and robot from a single manufacturer – no interface problems

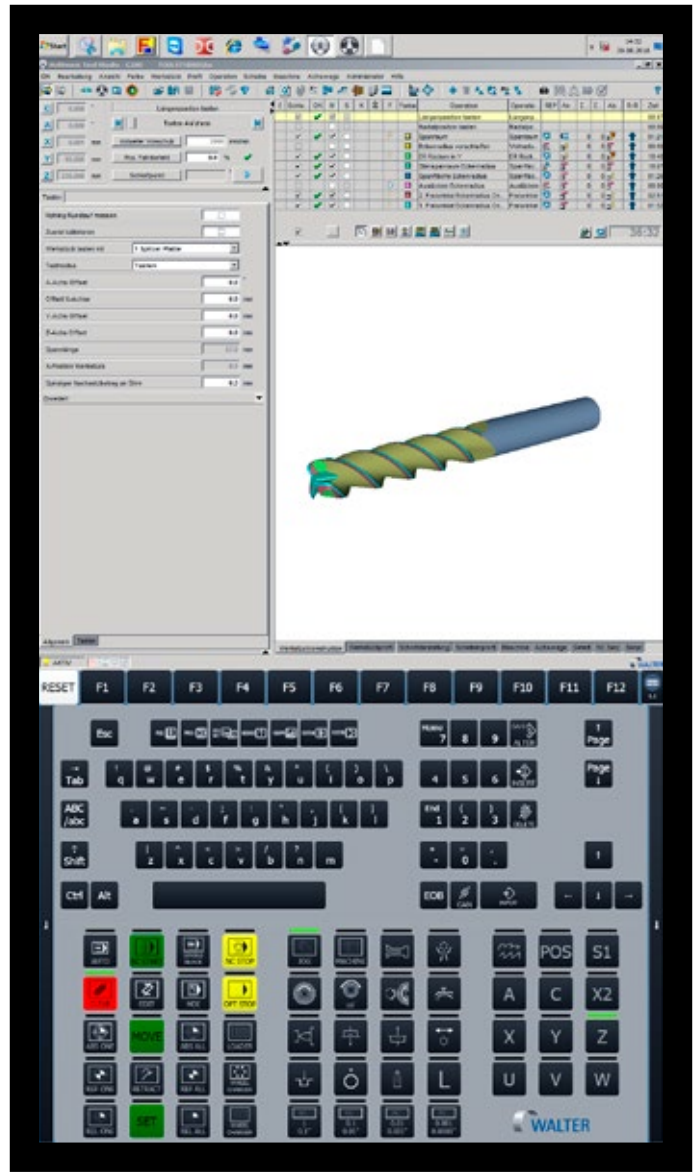

WE ARE HERE FOR YOU!

Our products are designed to meet customer demands for as long as possible, they are intended to operate efficiently, reliably, and be available at any time.

From “Start up” through to “Retrofit” – our Customer Care is there for you throughout the working life of your machine. For this reason, you can rely on competent HelpLines worldwide and Service Engineers near you:

- We will provide you with fast, straight-forward support.
- We will help to increase your productivity.
- We work professionally, reliably and transparently.
- We will provide a professional solution to your problems.



Start up
Commissioning
Extension of the guarantee

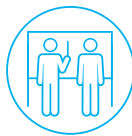

Qualification
Training
Product support



Prevention
Maintenance
Inspection



Service
Customer service
Customer advice
Helpline



Digital Solutions
Remote Service
Service Monitor
Production Monitor

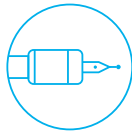

Material
Spare parts
Replacement parts
Accessories



Rebuild
Machine overhauling
Refurbishing of assemblies



Retrofit
Conversions
Retrofitting parts

UNITED GRINDING DIGITAL SOLUTIONS™

We develop solutions to support you in simplifying processes, boosting your machines’ efficiency and increasing overall productivity under the “UNITED GRINDING Digital Solutions™” brand.

Find out more about UNITED GRINDING Digital Solutions™ services on our website in the Customer Care section.



CUSTOMER CARE

TECHNICAL DATA, DIMENSIONS

MECHANICAL AXES

X axis	305 mm
Y axis	218 mm
Z axis	475 mm
Rapid traverse speed X, Y, Z	max. 15 m/min
C axis	+ 200°/- 110°
A axis	∞
Linear resolution	0.0001 mm
Radial resolution	0.0001°

GRINDING SPINDLE DRIVE

Max. grinding wheel diameter	150 mm
Grinding spindle speed	0 – 10,500 min ⁻¹

HELITRONIC G 200 with belt-driven spindle

Spindle ends	2
Tool holder	HSK 50
Peak power	9 kW
Diameter of spindle	80 mm

OTHERS

Weight of machine	approx. 4,200 kg
Connected value at 400 V/50 Hz	approx. 20 kVA

TOOL DATA 1)

Min. tool diameter for production/regrinding	1 mm/3 mm
Max. tool diameter for production/regrinding	16 mm/125 mm
Max. workpiece length of peripheral grinding ²⁾	235 mm
Max. workpiece length of face grinding ²⁾	195 mm
Max. workpiece weight	12 kg

OPTIONS

Automation options

Top loader

Coolant system

On request

Others

Software, various clamping systems based on a spring tension system, fire-extinguishing units, mist and vapour separator, automatic, electrical measurement of the machine reference, etc.

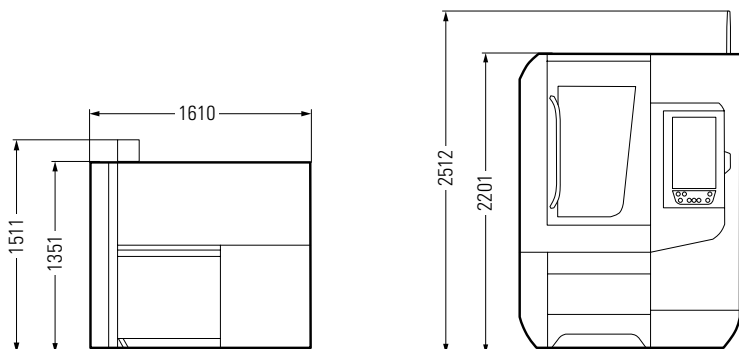

HELITRONIC G 200

Dimensions in mm. Options, accessories or open doors can increase the dimensions of the machine. Subject to modifications due to technical progress and errors. No guarantee is provided for this information.

- 1) The maximum tool dimensions depend on the type of tool and its geometry, as well as the type of machining.
- 2) From theoretical taper diameter of the workpiece holder.

CREATING TOOL PERFORMANCE

We are a global leader among market-oriented technology and service companies, and a system and solution partner for all areas of tool machining. Our range of services is the basis for innovative machining solutions for practically all tool types and materials typical for the market with a high degree of added value in terms of quality, precision, durability and productivity.



GRINDING

Grinding of rotation-symmetrical tools and workpieces, as well as indexable inserts

Machines	Use Materials	Tool dimensions ¹⁾ max. length ²⁾ / diameter
HELITRONIC G 200	P R HSS TC C/C	235 mm / Ø 1 – 125 mm
HELITRONIC ESSENTIAL	P R HSS TC C/C CBN	255 mm / Ø 1 – 100 mm
HELITRONIC MINI POWER	P R HSS TC C/C CBN	255 mm / Ø 1 – 100 mm
HELITRONIC MINI AUTOMATION	P R HSS TC C/C CBN	255 mm / Ø 1 – 100 mm
HELITRONIC RAPTOR	P R HSS TC C/C CBN	280 mm / Ø 3 – 320 mm
HELITRONIC POWER 400	P R HSS TC C/C CBN	520 mm / Ø 3 – 315 mm
HELITRONIC VISION 400 L	P R HSS TC C/C CBN	420 mm / Ø 3 – 315 mm
HELITRONIC VISION 700 L	P R HSS TC C/C CBN	700 mm / Ø 3 – 200 mm
HELITRONIC MICRO	P HSS TC C/C CBN R HSS TC C/C CBN	220 mm / Ø 0.1 – 12.7 mm 220 mm / Ø 3 – 12.7 mm
COMPACT LINE	P R HSS TC C/C CBN PCD	Indexable insert ¹⁾ Inscribed circle/ circumscribed circle Ø 3 mm / Ø 50 mm



LASER

Laser machining of indexable inserts and/or rotation-symmetrical tools

Machines	Use Materials	Tool dimensions ¹⁾ max. length ²⁾ / diameter
LASER LINE ULTRA	P R TC C/C CBN PCD CVD-D MCD/ND	250 mm / Ø 0.1 – 200 mm
LASER LINE PRECISION	P R CBN PCD CVD-D MCD/ND	250 mm / Ø 0.1 – 200 mm
Machines	Use Materials	Indexable insert ¹⁾ Inscribed circle/ circumscribed circle
LASER LINE ULTRA	P R TC C/C CBN PCD CVD-D MCD/ND	Ø 3 mm / Ø 50 mm
LASER LINE PRECISION	P R CBN PCD CVD-D MCD/ND	Ø 3 mm / Ø 50 mm



EROSION

Eroding and grinding of rotation-symmetrical tools

Machines	Use Materials	Tool dimensions ¹⁾ max. length ²⁾ / diameter
HELITRONIC DIAMOND EVOLUTION	P R HSS TC C/C CBN PCD	185/255 mm / Ø 1 – 165 mm
HELITRONIC RAPTOR DIAMOND	P R HSS TC C/C CBN PCD	270 mm / Ø 3 – 400 mm
HELITRONIC POWER DIAMOND 400	P R HSS TC C/C CBN PCD	520 mm / Ø 3 – 380 mm
HELITRONIC VISION DIAMOND 400 L	P R HSS TC C/C CBN PCD	420 mm / Ø 3 – 315 mm



MEASURING

Contact-free measurement of tools, workpieces and grinding wheels

Machines	Use E1-value	Tool dimensions ¹⁾ max. length ²⁾ / diameter
HELICHECK ADVANCED	M (1.8 + L/300) µm	420 mm / Ø 1 – 320 mm
HELICHECK PRO	M (1.2 resp. 1.4 + L/300) µm	300 mm / Ø 1 – 200 mm
HELICHECK PRO LONG	M (1.2 resp. 1.4 + L/300) µm	730 mm / Ø 1 – 200 mm
HELICHECK PLUS	M (1.2 resp. 1.4 + L/300) µm	300 mm / Ø 0.1 – 200 mm
HELICHECK PLUS LONG	M (1.2 resp. 1.4 + L/300) µm	730 mm / Ø 0.1 – 200 mm
HELICHECK 3D	M (1.8 + L/300) µm	420 mm / Ø 3 – 80 mm



SOFTWARE

The intelligence of tool machining and measuring for production and regrinding



CUSTOMER CARE

Comprehensive range of services

1) The maximum tool dimensions depend on the type of tool and its geometry, as well as the type of machining.

2) From theoretical taper diameter of the workpiece holder.

Use: P Production R Regrinding M Measuring

Materials: HSS High speed steel TC Tungsten carbide C/C Cermet/ceramics CBN Cubic boron nitride PCD Polycrystalline diamond

CVD-D Chemical vapour deposition MCD/ND Monocrystalline diamond/natural diamond

WALTER MASCHINENBAU GMBH

WALTER has produced tool grinding machines since 1953. Today, our product range is supplemented by tool eroding machines and fully automated CNC measuring machines of the HELICHECK series for contactless complete measurement of tools and production parts.

Walter Maschinenbau GmbH is a company of the UNITED GRINDING Group. Together with EWAG, we consider ourselves to be a supplier of systems and solutions for the complete machining of tools and can offer a wide range of products, including grinding, eroding, laser machining, measurement and software.

Our customer focus and our global sales and service network of company-owned locations and employees has been appreciated by our customers for decades.



Grinding



Eroding



Laser



Measuring



Software



Customer Care



ABOUT US

UNITED GRINDING GROUP

UNITED GRINDING Group is one of the world's leading manufacturers of precision machines for grinding, eroding, laser, measuring and combination machining. With around 2,500 employees at more than 20 production, service and sales sites, the Group is organized in a customer-oriented and efficient way.

With its brands MÄGERLE, BLOHM, JUNG, STUDER, SCHAUDT, MIKROSA, WALTER, and EWAG as well as competence centers in America and Asia UNITED GRINDING offers an ample range of application expertise, an extensive product portfolio and an array of services for surface and profile grinding, cylindrical grinding and tool machining. In addition, a competence center for additive manufacturing is operated under the IRPD brand.

« We want to make our customers even more successful »

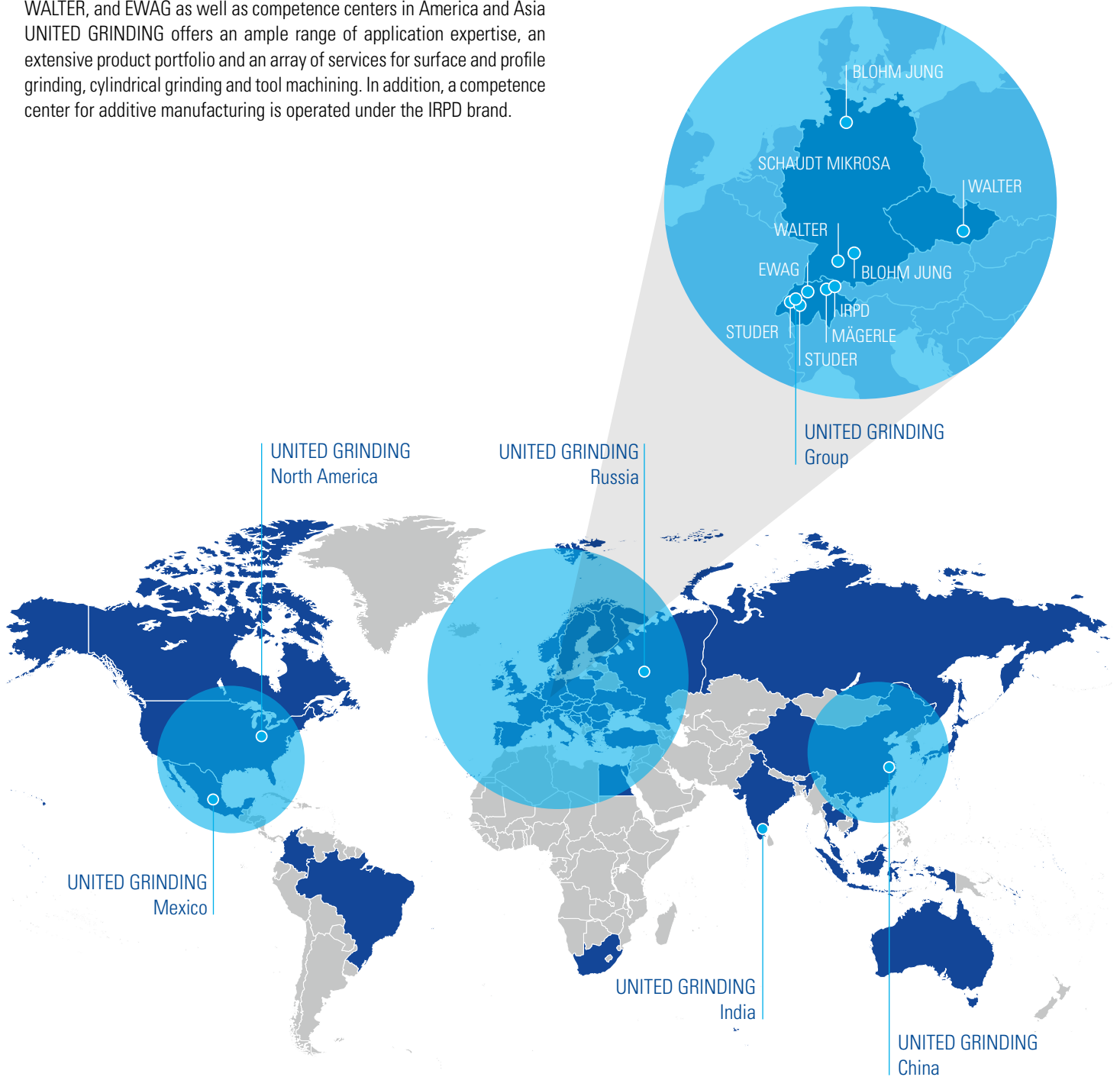



Walter Maschinenbau GmbH
Jopestr. 5 · 72072 Tübingen, Germany
Tel. +49 7071 9393-0
info@walter-machines.com

For worldwide contact details, please visit
walter-machines.com

